



INTERNATIONAL JOURNAL OF ENGINEERING SCIENCES & RESEARCH TECHNOLOGY

Classification of Transmission Line Faults Using Wavelet Transformer

B. Lakshmana Nayak

M.TECH(APS), AMIE, Associate Professor, Nalla Malla Reddy Engineering College, Hyderabad, A.P,
India

lakshmananayak@gmail.com

Abstract

In general fault analysis is carried out for a given system assuming various types of fault currents are estimated based on the configurations. It is proposed to implement Discrete Wavelet Transformer (DWT) approach for fault classification once the fault currents are known in a particular location. Daubechies eight (D-8) wavelet transforms of the three phase currents on a transmission line fed from both ends is used. An algorithm is implemented for the classification of faults in the transmission line using MATLAB-SIMULINK software.

The advent of large generating stations and highly interconnected power systems makes early fault detection and rapid equipment isolation imperative to maintain system stability. In analyzing the fault are existing methods like Fourier analysis, Short Time Fourier Transforms and Fast Fourier Transforms have the limitations of fixed window and poor resolution. If wavelet transforms are opted, they overcome the above disadvantages, as wavelet transforms employ analysis functions that are localized both in time and frequency domain. It focuses on short-time intervals for high frequency components and long-time intervals for low frequency components. Wavelets have a window that automatically adapts to give appropriate resolution.

Keywords: Transmission line faults, wavelet Transforms

Introduction

The demand for electricity is ever increasing. It is very important to supply quality electrical power continuously for industrial, business and residential usage. While failure to supply electricity to residential areas might result in Prevalent.

Power system faults not only can cause discontinued supply, they can also damage the power little in the system equipment that is costly to replace. This will also bring further halt in supplying electricity. Fortunately, those faults can be detected and isolated soon before they cause further damage to equipment.

This project focuses the use of wavelet transform, a unified framework for analyzing power system fault classification in a line. Wavelet transform [1] possesses excellent features such as a little wave, little in the sense of being of short duration with finite energy which integrates to zero. Wavelet is well suited to wide band signals that are not periodic and may contain both sinusoidal and impulse components as it is typical for power system transients.

Any random signal can be represented as sum of wavelet functions. Wavelet transform transforms the time-amplitude information into time-scale information. The advantage of this technique is that, both time and frequency domain information can be obtained. Using wavelet transforms the waveforms that occur during switching operations, transients, faults etc., can be

analyzed so that more accurate analysis can be obtained . Wavelet transforms are practically realized user filter banks.

In this paper, a new scheme is proposed for fast and reliable fault classification. The proposed method uses a wavelet-based scheme. Various faults are modeled and a wavelet based algorithm [2] is used for the classification of faults. Performance of the proposed scheme is evaluated using various fault types.

Need for Fault Classification

In case power system disturbances, control center dispatches must use the possible judgment and experience to determine the possible faulted elements as the first step in the restoration procedures. When the breaker or its associated relays fail to operate, the fault is removed by its backup protection. In such cases, the outage is very and it is difficult for the dispatchers to estimate the fault location. Moreover, the multiple faults eventually take place, with many circuit breakers being tripped within a very short time. In these circumstances so many alarm messages will be transmitted to the dispatch center that it is impossible for the dispatchers to analyze the situation satisfactorily and ensure that the most appropriate actions to be taken. Therefore, it is important to develop some means of providing accurate fault analysis to assist dispatchers in these situations.

A protection scheme continuously monitors the power system to ensure maximum continuity of electrical supply with minimum damage to life, equipment and property. The stability of the interconnected power system is its stability to return to normal or stable operation after having been subjected to some form of disturbance. To maintain the stability of the system the fault has to be quickly diagnosed and rectified. Transmission line fault has been one of the primary concerns of the power industry. This paper focuses the use of Wavelet transforms, a unified framework for analyzing power system power system in the transmission lines in the identification of various types of faults.

Need for Wavelet Transforms

In power system, wavelet transforms (WTs) are better suited for the analysis of certain types of transient waveforms than the Fourier Transforms (FT) and Short-Time Fourier Transforms (STFT) approaches [3]. A wavelet is described as a little wave, little in the sense of being of short duration with finite energy with integrates to zero, and hence its suitability for transients. Power system transients, which often have an adverse effect on the nominal operation of the system, are quite common like, lighting transients, transformer inrush currents, motor starting currents, capacitor and line-switching transients are just a few of the typical electromagnetic power system transients [4] that occur in practice. Some of the methods employed for analysis of the transient phenomena at present are, transforming the data into the frequency domain via Fourier and STFT [5, 6].

Fourier series have a few drawbacks, they require periodicity in all the time functions involved and also location of transient in all time axis is lost [7]. STFT have the limitations of fixed window width and it will consume more time in transient location.

If Wavelet transforms are opted, they overcome the above discussed disadvantages, as Wavelet transforms employ analysis functions that are localized both in time and frequency domain. It focuses on short-time intervals for high frequency components. Wavelets have a window that automatically adapts to give appropriate resolution.

Power System Simulation Model

Any power system model can be simulated using power system block set and simulink in MATLAB 7.1. A Wavelet technique is used for classification of faults in power system model. Consider the single line diagram of a sample power system shown in Fig. 1.

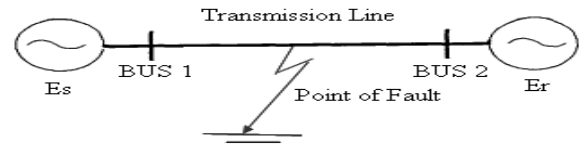

Fig. 1. Single line diagram of a sample power system
Where Es: Sending end voltage
Er: Receiving end voltage

The diagram shown in Fig. 2 represents the Simulink block model for Fig. 1 which consists of a three phase 66KV power system transmitting power from two 25 MVA generators on either side of a 300km transmission line. The transmission line is split into two 150km lines connected between busses B1 and B2. The system consists of two generator (simplified synchronous machines), two three phase two winding transformers, two circuit breakers, a transmission line and a three phase fault block.

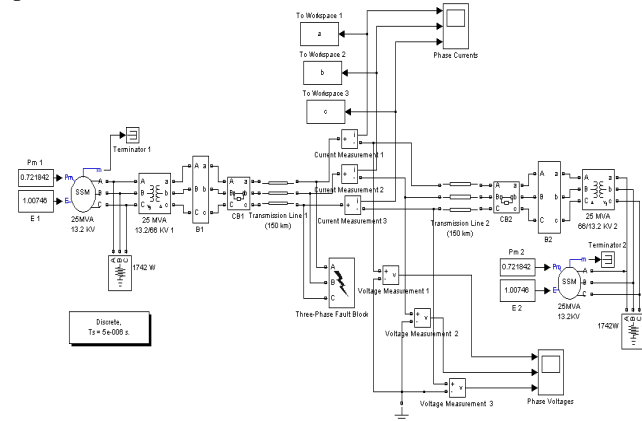

Fig. 2. Block Diagram of Power System Model

Selection of Mother Wavelet Transforms

Selecting the most suitable mother wavelet enhance the ability of the fault detection technique to extract the useful information rapidly. One can accurately identify the faulted phase and so as to improve the speed of the fault detection. In order to select the optimal mother wavelet, the absolute values of the d1 coefficients are summated over one cycle window. The selection of mother wavelet is based on the magnitude summation of the summated coefficients d1 and the difference in magnitude between the faulted and healthy phases. In this respect after a series of studies it has been found practically in different system and fault conditions, both db4 and sym5 seen to be less effective to detect fault on the transmission lines and it has less effective to detect fault on the transmission lines and it has been found that db8 is best suited for power system applications [2].

Fault Classification Algorithm

Types of faults considered in the analysis are LG, LL, LLG and LLLG faults. The parameter for the classification of faults is the summation of 3rd level output for the three phase currents.

The algorithm [2] proceeds as follows:

Let S_a = Summation of 3rd level values for current in phase 'a'

S_b = Summation of 3rd level values for current in phase 'b'

S_c = Summation of 3rd level values for current in phase 'c'

Step 1: If $S_a + S_b + S_c \approx 0$, then the fault is classified as L-L-L-G fault. In this case the magnitude of all the summation values S_a and S_c are comparable to each other.

Step 2: If $S_a + S_b + S_c \approx 0$ and also if sum of any two of the summations S_a , S_b and S_c is equal to zero, i.e., the magnitude of the summation is very small and almost negligible in comparison to the equal magnitudes of other two summations, then the fault is classified as LL fault.

i.e., If $S_a + S_b = 0$, then it implies that L-L fault has occurred between a and b phases

If $S_b + S_c = 0$, then it implies that L-L fault has occurred between b and c phases

If $S_a + S_c = 0$, then it implies that L-L fault has occurred between a and c phases

Step 3: If $S_a + S_b + S_c \neq 0$, then it is either a L-G or L-L-G fault.

If the absolute value of any two summations (S_a , S_b , S_c) is equal and is always much smaller than the absolute value of the 3rd summation, then it is a L-G fault

i.e If $|S_b| = |S_c| \ll S_a$, then it implies that L-G fault has occurred between phase a and ground

If $|S_a| = |S_c| \ll S_b$, then it implies that L-G fault has occurred between phase b and ground

If $|S_a| = |S_b| \ll S_c$, then it implies that L-G fault has occurred between phase c and ground

Step 4: If the absolute value of any two summations (S_a , S_b , S_c) are not equal and are always much higher than the absolute value of the 3rd summation, then it is a L-L-G fault.

If $S_{min} = \min(S_a, S_b, S_c)$, then

If $S_{min} = S_c \ll S_a$ or S_b , then it implies that L-L-G fault has occurred between phases a, b and ground.

If $S_{min} = S_b \ll S_a$ or S_c , then it implies that L-L-G fault has occurred between phases a, c and ground.

If $S_{min} = S_a \ll S_b$ or S_c , then it implies that L-L-G fault has occurred between phases b, c and ground.

The complete flow chart for the fault classification [2] is as shown in Fig 3.

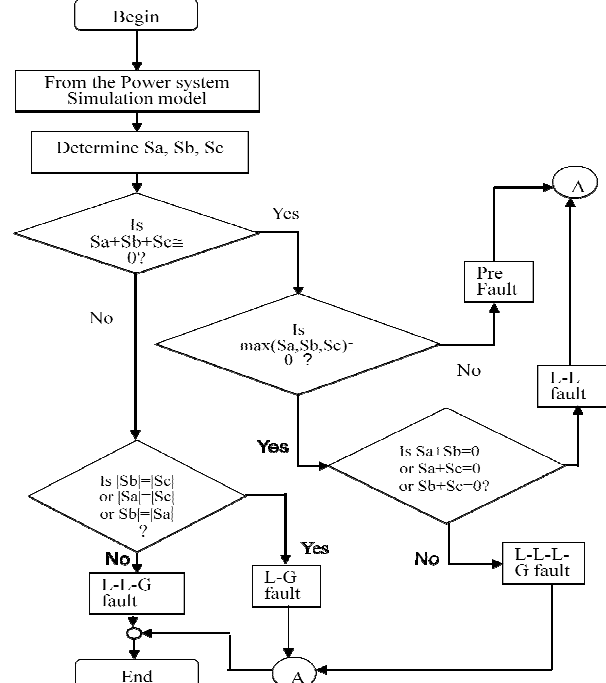

Fig. 3 Flow-Chart for the Fault Classification

Pre-Fault:

The phase voltage waveforms of the power system model for Pre-fault condition are shown in Fig 4.

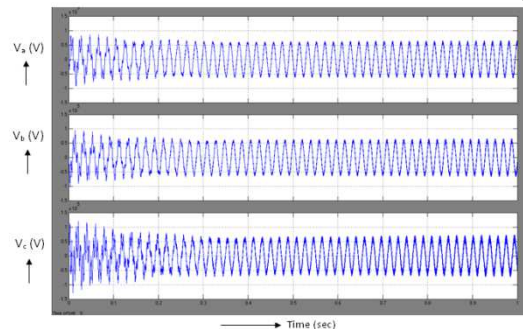

Fig. 4 Phase Voltage Waveforms for Pre-Fault

The phase current waveforms of the power system model for Pre-fault condition are shown in Fig 5.

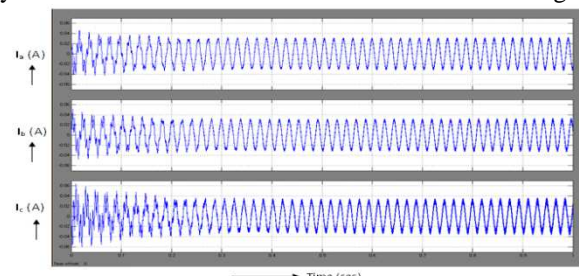

Fig. 5 Phase Current Waveforms for Pre-Fault

The values of S_a , S_b , and S_c for Pre-Fault condition are given by

$$\begin{aligned} S_a &= 0 \text{ A,} \\ S_b &= 0 \text{ A \&} \\ S_c &= 0 \text{ A} \\ S_a + S_b + S_c &= 0 \end{aligned}$$

The condition $S_a + S_b + S_c \geq -1$ && $S_a + S_b + S_c \leq 1$ is satisfied and $\max [(S_a, S_b, S_c)] \leq 1$ is also satisfied. So from the MATLAB program the condition of the system is Pre-Fault condition and corresponding result obtained from MATLAB is as shown in Fig. 6.



Fig. 6 Matlab Result for Pre-Fault

LLG Fault between Phase A, B, C and Ground:

The phase voltage waveforms of the power system model when a three phase to ground fault has occurred between phases A, B, C and Ground at the midpoint of the transmission line connected between Buses B1 and B2, are as shown in Fig. 7.

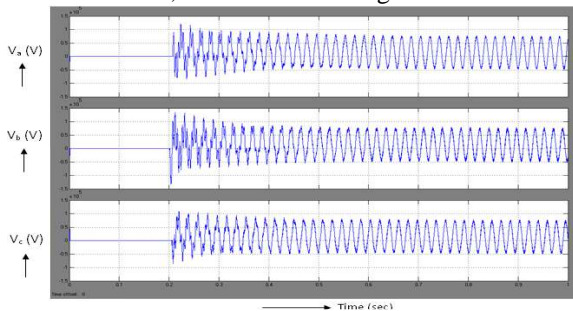

Fig. 7 Phase Voltage Waveforms for LLLG Fault

It can be observed that the Phase Voltages are zero during the time of fault. After the fault is cleared, the phase voltage reaches to the steady state after initial transient voltages are over. The steady state Phase Voltages are higher than that under Pre-Fault condition.

The Phase Current waveforms of the power system model under LLLG fault are shown in Fig. 8.

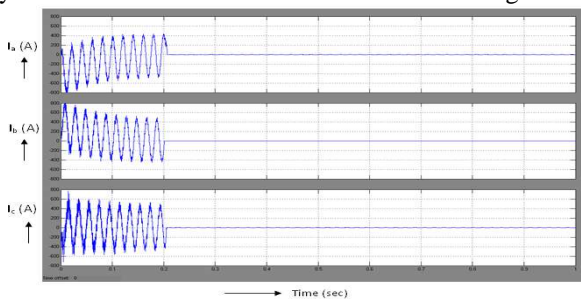

Fig. 8 Phase Current Waveforms for LLLG Fault

It can be observed that the Phase Current are more than that under Pre-Fault condition and current reaches to zero after the cleared.

The values of Phase Currents taken from the Fig. 5 at time $t = 0.15$ sec (under steady state) are given below.

$$\begin{aligned} I_a &= 500 \text{ A} \\ I_b &= 300 \text{ A} \\ I_c &= 200 \text{ A} \end{aligned}$$

For a LLLG fault the fault current is the phasor sum of the r.m.s. values of phase currents.

$$\text{Fault Current } I_f = I_a + I_b + I_c = 344.112 \text{ A}$$

The value of Fault Current calculated theoretically is 326.625 A. A difference of 17.45 A has appeared between the two values, because of the Fault resistance in the Three-Phase Fault block, resistances connected in parallel with Simplified synchronous machines of power system model shown in Fig. 2, which are neglected in the theoretical calculation of Fault current. Hence the result is verified for LLLG Fault, the same procedure can be adapted to other Faults also.

The values of S_a , S_b and S_c for LLLG Fault are given by

$$\begin{aligned} S_a &= 50 \text{ A,} \\ S_b &= 67 \text{ A \&} \\ S_c &= -118 \text{ A} \\ S_a + S_b + S_c &= -1 \end{aligned}$$

The condition $S_a + S_b + S_c \geq -1$ && $S_a + S_b + S_c \leq 1$ is satisfied and the condition $\max [(S_a, S_b, S_c)] \leq 1$ is not satisfied. The fault is either LL Fault or LLLG Fault.

As the conditions $S_a + S_b \geq -1$ && $S_a + S_b \leq 1$, $S_b + S_c \geq -1$ && $S_b + S_c \leq 1$ and $S_a + S_c \geq -1$ && $S_a + S_c \leq 1$ are not satisfied, so from the MATLAB program it can be calculated that LLLG fault has occurred between phases A, B, C and Ground, the corresponding result obtained from MATLAB is as shown in Fig. 9.



Fig. 9 Matlab Result for LLLG Fault

LLG Fault between Phase B, C and Ground:

The phase voltage waveforms of the power system model when a Double line to ground fault has occurred between phases B, C and Ground at the midpoint of the transmission line connected between Buses B1 and B2, are as shown in Fig. 10.

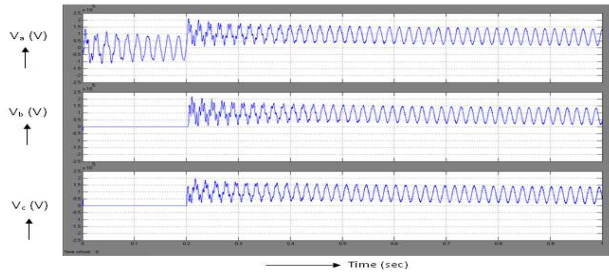

Fig. 10 Phase Voltage Waveforms for LLG Fault

It can be observed that the Phase Voltages are zero for phases B and C during the time of fault. After the fault is cleared, the phase voltage reaches to the steady state after initial transient voltages are over. The steady state Phase Voltages are higher than that under Pre-Fault condition.

The Phase Current waveforms of the power system model LLG fault are shown in Fig. 11.

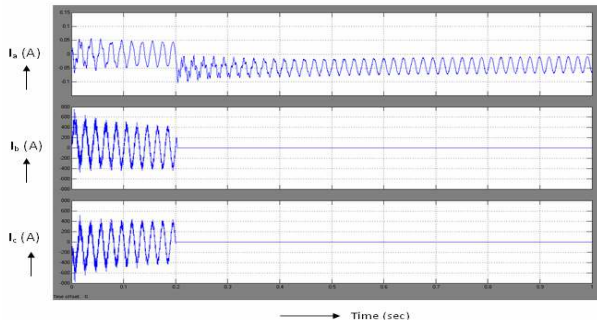

Fig. 11 Phase Current Waveforms for LLG Fault

It can be observed that the Phase Current are more than that under Pre-Fault condition and current reaches to zero in phases B and C after the fault is cleared.

The values of \$S_a\$, \$S_b\$ and \$S_c\$ for LLG Fault between phases B, C and Ground are given by

$$\begin{aligned} S_a &= 0 \text{ A,} \\ S_b &= 87 \text{ A \&} \\ S_c &= -97 \text{ A} \\ S_a + S_b + S_c &= -10 \end{aligned}$$

So the conditions $S_a + S_b + S_c > -1$ && $S_a + S_b + S_c <= 1$ is not satisfied. The fault is either LG Fault or LLG Fault. The conditions $\text{abs}(S_a) == \text{abs}(S_b), \text{abs}(S_a) == \text{abs}(S_c), \text{abs}(S_b) == \text{abs}(S_c), (\text{Smin} == \text{abs}(S_c) \parallel \text{Smin} < \text{abs}(S_a) \&\& \text{Smin} < \text{abs}(S_b))$ are not satisfied and the Conditions $(\text{Smin} == \text{abs}(S_a) \parallel \text{Smin} < \text{abs}(S_b) \&\& \text{Smin} < \text{abs}(S_c))$ is satisfied. So from the MATLAB Program, it can be concluded that LLG Fault has occurred between phases B, C and Ground and corresponding result obtained from MATLAB is as shown in Fig.12.



Fig. 12 Matlab Result for LLG Fault

LL Fault between Phase B and C :

The phase voltage waveforms of the power system model when a Line to Line fault has occurred between phases B and C at the midpoint of the transmission line connected between Buses B1 and B2, are as shown in Fig. 13.

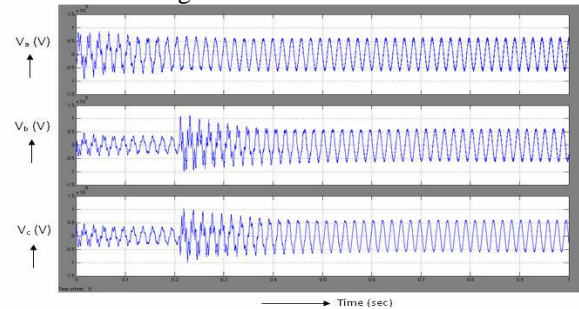

Fig. 13 Phase Voltage Waveforms for LL Fault

It can be observed that the Phase Voltages have some finite value during the time of fault. After the fault is cleared, the phase voltage reaches to the steady state after initial transient voltages are over. The steady state Phase Voltages are higher than that under Pre-Fault condition.

The Phase Current waveforms of the power system model LL fault are shown in Fig. 14.

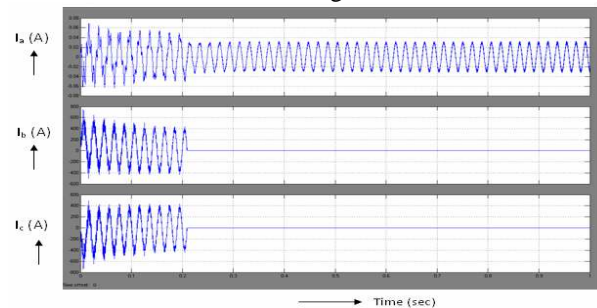

Fig. 14 Phase Current Waveforms for LL Fault

It can be observed that the Phase Current are more than that under Pre-Fault condition and current reaches to zero in phases B and C after the fault is cleared.

The values of \$S_a\$, \$S_b\$ and \$S_c\$ for LL Fault between phases B and C are given by

$$\begin{aligned} S_a &= 0 \text{ A,} \\ S_b &= 92 \text{ A \&} \\ S_c &= -92 \text{ A} \\ S_a + S_b + S_c &= 0 \end{aligned}$$

So the condition $S_a + S_b + S_c > -1$ && $S_a + S_b + S_c <= 1$ is satisfied and the condition $\text{max} [(S_a,$

$S_b, S_c] \leq 1$ is not satisfied the fault is either LL fault or LLLG fault. The condition $(S_a + S_b \geq -1) \&\& (S_a + S_b \leq 1)$ is not satisfied and the condition $(S_b + S_c \geq -1) \&\& (S_b + S_c \leq 1)$ is satisfied. So from the MATLAB Program, it can be concluded that LL Fault has occurred between phases B and C and corresponding result obtained from MATLAB is as shown in Fig.15.



Fig. 15 Matlab Result for LL Fault

LG Fault between Phase A and Ground :

The phase voltage waveforms of the power system model when a single Line to Ground fault has occurred between phases A and Ground at the midpoint of the transmission line connected between Buses B1 and B2, are as shown in Fig. 16.

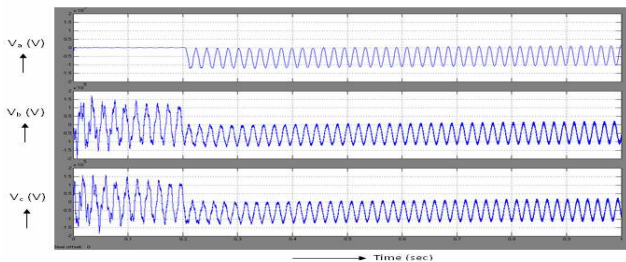

Fig. 16 Phase Voltage Waveforms for LL Fault

It can be observed that the Phase Voltage in phase A is zero during the time of fault. After the fault is cleared, the phase voltage reaches to the steady state after initial transient voltages are over. The steady state Phase Voltages are higher than that under Pre-Fault condition.

The Phase Current waveforms of the power system model LG fault are shown in Fig. 17.

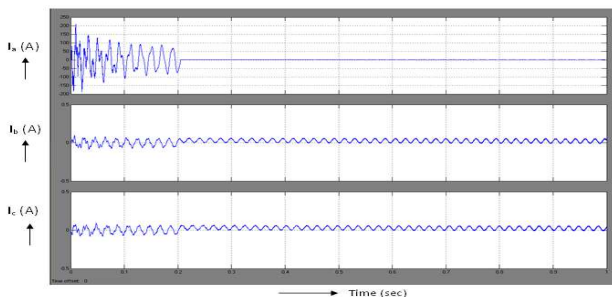

Fig. 17 Phase Current Waveforms for LG Fault

It can be observed that the Phase Current are more than that under Pre-Fault condition and current reaches to zero in phase A after the fault is cleared. The values of S_a, S_b and S_c for LG Fault between phases A and Ground are given by

$$S_a = 20 \text{ A,}$$

$$S_b = 0 \text{ A \&}$$

$$S_c = 0 \text{ A}$$

$$S_a + S_b + S_c = 20$$

So the condition $S_a + S_b + S_c \geq -1 \&\& S_a + S_b + S_c \leq 1$ is not satisfied, hence the fault is either LG fault or LLG fault. As the condition $\text{abs}(S_b) = \text{abs}(S_c)$ is satisfied. So from the MATLAB Program, it can be concluded that LG Fault has occurred between phases A and Ground and corresponding result obtained from MATLAB is as shown in Fig.18.



Fig. 18 Matlab Result for LG Fault

Analysis of Result

From the results given in Section 2.2.1.to 2.2.5, it can be concluded observed that when a fault occurred in the transmission line, the current flowing through the faulted line was increased and the voltage across the faulted line was increased and the voltage across the faulted phases decreased and it drops down to zero when fault occurred involving Ground.

Conclusions

The work carried out in this paper has been concentrated on implementing an effect algorithm for the classification of faults in the transmission line of power system model. Wavelet analysis, an entirely new approach is presented for the classification of faults. The Wavelet analysis is performed on different currents recorded for various types of faults and the observations are made as follows:

- a).The decomposition and reconstruction of transients is straightforward with discrete Wavelet analysis.
- b).By using discrete Wavelet analysis distinction has been made among various types of faults occurring in the transmission line of power systems model. To obtain this analysis Daubechies eight (D-8) Wavelet is used.
- c).The proposed Wavelet based method reduces the quantity of extracted features of the line current signals, thus requires less memory space and commutating time for proper classification of fault types.

The simulation results show that the proposed method has the ability of classifying different fault types quite accurately and efficiently. Hence , it can be concluded that Wavelet based method is better choice for fault classification of faults as compared to Fourier transforms.

Future Scope

As a consequence of the investigation carried out in this paper on evolving efficient method for fault classification in transmission lines in the power system model following aspects are identified for future research work in this area.

The algorithm presented in this paper can be extended for the classification of faults in the transformer such as insulation faults, intermittent fault, inter turn fault.

The proposed model can be extended for identifying the fault location on the transmission lines.

The proposed model can also be extended to identify other power quality disturbances such as voltage sag, impulse disturbance, oscillatory transients etc.

References

- [1] S. G. Mallat, "A Theory for Multi Resolution Signal Decomposition: The Wavelet Presentation", *IEEE Transactions on Pattern Analysis and Machine Intelligence*, Vol. 11, No. 7, 1989, pp.674-693.
- [2] D. Chanda, N. K. Kishore, A. K. Sinha, "Application of Wavelet Multi resolution Analysis for Location of Faults on Transmission Lines", *Proceedings of TENCON 2003*, pp.1464-1468.
- [3] Chul-Hwan Kim, Raj K. Aggarwal, "Wavelet transforms in power systems", *power engineering journal August 2001*, pp.193-202.
- [4] David C.Robertson, Octavia I.Camps, J. S. Mayer, William B. Gish, "wavelet and Electromagnetic power system Transients", *IEEE Transactions on Power Delivery*, April 1996, Vol. 11, No. 2, pp.1050-1058.
- [5] T. M. Lai, L. A. Snider, E. Lo, and D. Sutanto, "High-Impedance Fault Detection Using Discrete Wavelet Transform and Frequency Range and RMS Conversion", *IEEE Transactions on Power Delivery*, January 2005, Vol. 20, No. 1, pp.397-407.
- [6] M. Solanki, Y. H. Song, S. Potts, A. Perks, "Transient protection of transmission line using wavelet transforms", *Developments in power system protection, conference publication No.479, IEEE 2001*, pp.299-302.
- [7] D. Das, N. K. Singh, A. K. Sinha, "A Comparision of Fourier Transforms and WaveletTranfor Methods for Detection and Classification of Faults on Transmission lines", *IEEE Transactions on Power Delivery*, 2005, Vol. 20, pp.250-257.